

means for adjusting the end of a shutter independently, so that the flow of the heated air of one end of a car or other apartment may be

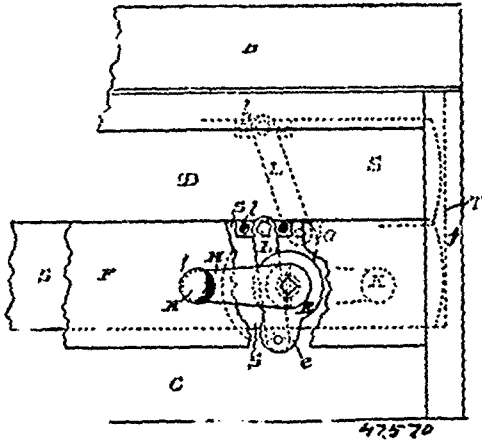

47570

controlled without affecting the flow of air to the other end of the same, substantially as described and for the purpose set forth.

**No. 47,571. Screw Cutting Machines. (Filères à vis.)**

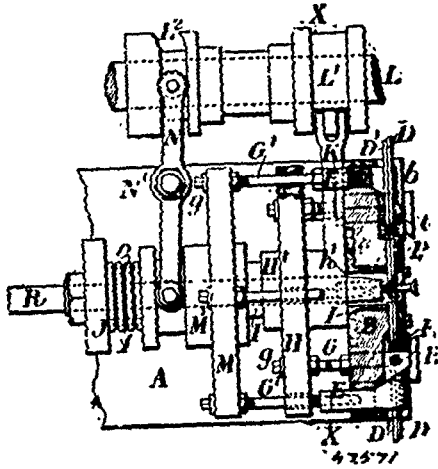

47571

Thomas Benjamin Smith, of Birmingham, England, 3rd December, 1894; 6 years.

*Claim.*—1st. In a screw-cutting machine in which a number of cutters or operating tools are made to advance in a radial direction to operate upon a centrally situated screw-blank, the combination with a face plate B, of radially sliding blocks C, holding the tools and having inclines c, bars E, sliding through the face plate in a direction parallel or nearly so with the axis of the machine, and having inclines e, adapted to force the blocks C, and tools radially inwards when the bars are moved in a backward direction, springs F, adapted to force the blocks C, and tools radially outward on the forward motion of the bars E, and means for imparting a to and fro motion to the said bars, substantially as described. 2nd. In a screw-cutting machine, the combination with a face plate B, of radially sliding blocks C, holding the tools and having inclines c, bars E, sliding through the face plate and having inclines e, adapted to force the blocks C, and tools radially inwards when the bars are moved in a backward direction, springs F, adapted to force the blocks C, and tools radially outwards on the forward motion of the bars E, a disc H, carrying screwed stems G, adjustably connected to the bars E, a sliding sleeve H<sup>1</sup>, forming part of disc H, and having inclined faces, and a sliding arm K, with inclines operating against the inclines of the sleeve H<sup>1</sup>, and an appliance for moving the said arm forward, so as to force backward, the sleeve H, substantially as described. 3rd. In a screw-cutting machine, the combination with a face plate B, of radially sliding blocks C, carrying the operating tools D, D<sup>1</sup>, D<sup>2</sup>, and sliding in grooves in the face plate, bars E, sliding through the face plate having inclines operating against inclines on the blocks C, and slots through which the tools D, D<sup>1</sup>, D<sup>2</sup>, pass screwed stems G, screwing into threaded holes in the bars E, and rotatably secured in a disc H, and means for imparting a to and fro motion to the said disc, substantially as described.

**No. 47,572. Manufacture of Metal Boxes.**

(Fabrication de boîtes métalliques.)

Emile René Pettier, Paris, France, 3rd December, 1894; 6 years.

*Claim.*—1st. In the manufacture of sardines and like metal boxes

forming the body of the box from a blank having a small tongue projecting therefrom, thinning the metal blank along two parallel lines extending from the said tongue, and doubly folding the blank below the thinned portion, substantially as and for the purpose

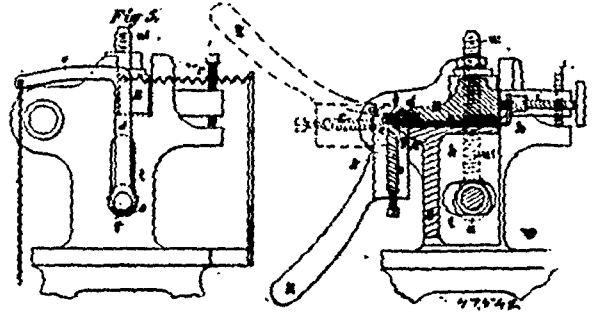

hereinbefore described. 2nd. The machine for doubly folding the bodies of sardine and like metal boxes at a single stroke, such machine comprising a plate e and grooved counter plate d, arms for bringing the edge of the plate e into engagement with the groove in the plate d, and an arrangement of spring and eccentric for keeping the plate d raised and treadle for lowering the said plate, substantially as hereinbefore described.

**No. 47,573. Box Ending Machine.**

(Machine à poser les bouts des boîtes.)

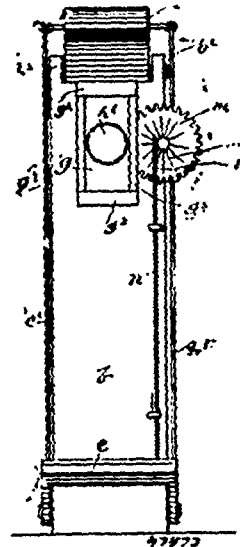

47573

William Thomas Miller, Montreal, Quebec, Canada, 3rd December, 1894; 6 years.

*Claim.*—1st. A box-ending machine having an intermittently rotatable work support. 2nd. In combination with a box-ending machine, a work support or form variable in size. 3rd. In combination with a box-ending machine, a work support or form variable in size and shape. 4th. In a box-ending machine, the combination with a depressor, of a rotatable work support or form for the purpose set forth. 5th. In a box-ending machine, the combination with the frame or standard, of a vertically adjustable work support and means for exerting a pressure upon the upper end of such work support for the purpose set forth. 6th. In a box-ending machine, the combination with the frame or standard, of a vertically adjustable work support, a depressor for exerting a pressure upon the upper end of such work support and means for operating said depressor and securing the intermittent rotation of such work support, for the purpose set forth. 7th. In a box-ending machine, the combination of a standard having a vertical slot near its upper end a rotatable and variable work support the trunnion or spindle of which is adjustably carried in said slot, a depressor pivotally mounted in said standard, means for rotating said work support and for raising and for lowering same, for the purpose set forth.

**No. 47,574. Sole Rounding Machine.**

(Machine pour arrondir les semelles.)

The Globe Buffer Company, assignees of Lewis E. Ericson, both of Boston, Massachusetts, U.S.A., 3rd December, 1894; 6 years.

*Claim.*—1st. In a sole-rounding machine, the combination of the