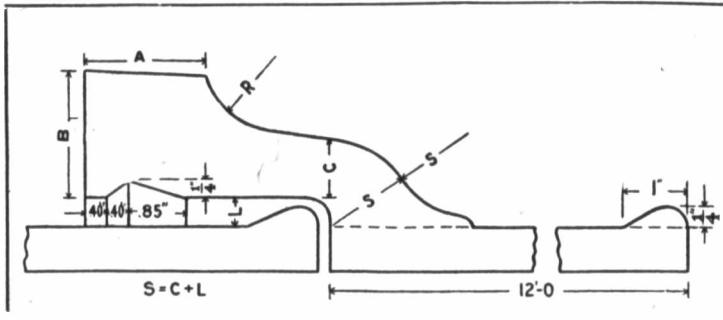

TABLE NO. 3.

General Dimensions of Pipe.

FOR FIRE LINES AND OTHER HIGH-PRESSURE SERVICE.



Nominal Diam. Inches.	CLASSES.	Actual Outside Diam. Inches.	DIAM. OF SOCKETS.	DEPTH OF SOCKETS.	A.	B.	C.	R.	Nominal Diam. Inches.
			Pipe and Specials.	Pipe and Specials.					
6	E-F	7.22	8.02	4.00	1.50	1.75	.75	1.10	6
6	G-H	7.38	8.18	4.00	1.50	1.85	.85	1.10	6
8	E-F	9.42	10.22	4.00	1.50	1.85	.85	1.10	8
8	G-H	9.60	10.40	4.00	1.50	1.95	.95	1.10	8
10	E-F	11.60	12.40	4.50	1.75	1.95	.95	1.10	10
10	G-H	11.84	12.64	4.50	1.75	2.05	1.05	1.10	10
12	E-F	13.78	14.58	4.50	1.75	2.05	1.05	1.10	12
12	G-H	14.08	14.88	4.50	1.75	2.20	1.20	1.10	12
14	E-F	15.98	16.78	4.50	2.00	2.15	1.15	1.10	14
14	G-H	16.32	17.12	4.50	2.00	2.35	1.35	1.10	14
16	E-F	18.16	18.96	4.50	2.00	2.30	1.25	1.15	16
16	G-H	18.54	19.34	4.50	2.00	2.55	1.45	1.15	16
18	E-F	20.34	21.14	4.50	2.25	2.45	1.40	1.15	18
18	G-H	20.78	21.58	4.50	2.25	2.75	1.65	1.15	18
20	E-F	22.54	23.34	4.50	2.25	2.55	1.50	1.15	20
20	G-H	23.02	23.82	4.50	2.25	2.85	1.75	1.20	20
24	E-F	26.90	27.90	5.00	2.25	2.85	1.70	1.20	24
30	E	33.10	34.10	5.00	2.25	3.25	1.80	1.50	30
30	F	33.46	34.46	5.00	2.25	3.50	2.00	1.55	30
36	E	39.60	40.60	5.00	2.25	3.70	2.05	1.70	36
36	F	40.04	41.04	5.00	2.25	4.00	2.30	1.80	36