

1½ to 20
H.P.

Stationary
or Portable

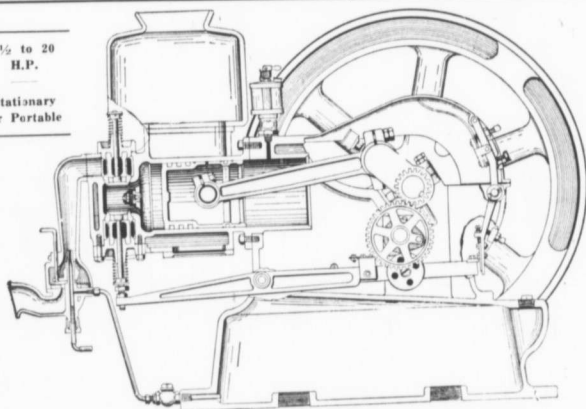

The Massey-Harris Gasoline Engine

is the simplest High-Class Engine on the Market.

Simplicity—with Efficiency—is the Keynote in the Massey-Harris Engine.

☞ It has fewer parts than any other high-class Engine on the market, yet no other Engine is so reliable and efficient under the various conditions met with in actual work.

☞ The Mixer is the simplest possible construction, but gives higher efficiency and is more economical of gasoline than any other.

☞ The Cylinder, Cylinder Head and Water Jacket are cast solid—no gaskets or packed joints to give trouble.

☞ The Water Jacket extends around the Cylinder Head and Valves, and the Valves are extra large—no danger of overheating.

☞ The Combustion Chamber and Spark Plug are placed in the end of Cylinder, ensuring quick combustion and direct action on the Piston.

Massey-Harris Company, Limited

Branches at

Montreal, Moncton, Winnipeg, Regina, Saskatoon, Yorkton, Calgary, Edmonton.

Head Offices—TORONTO, CANADA

—Agencies Everywhere—