

# The Canadian Patent Office

## RECORD





Vol. XXVIII.—No. 5.

MAY 31st, 1900.

Price free by post in Canada and the United States, \$2.00.  
SINGLE NUMBERS, - - - 20 Cts

### NOTICE.

All solicitors, agents or attorneys who, in circulars or advertisements, or otherwise, refer to the Commissioner or Deputy Commissioner of Patents, or to any other official of the Patent Office, for evidence of their professional standing, do so without authority.

### INVENTIONS PATENTED.

NOTE.—Patents are granted for 18 years. The term of years for which the fee has been paid, is given after the date of the patent.

#### No. 67,167. Cut-off Valve Gear.

(*Détente pour soupapes d'engrenage.*)

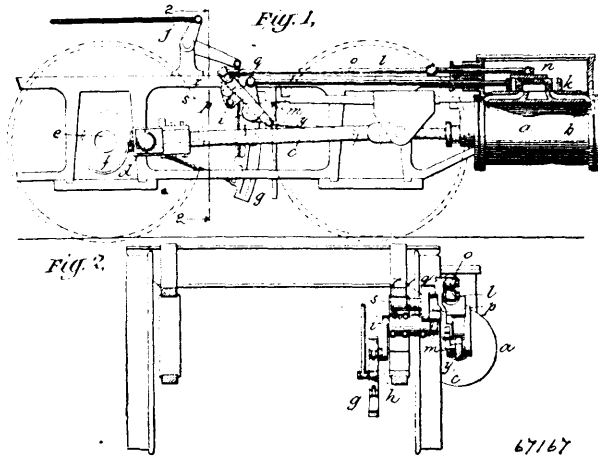

Robert Hardie, Chicago, Illinois, U.S.A., 1st May, 1900; 6 years. (Filed 5th April, 1900.)

Claim.—1st. In an engine, the combination with a cylinder, a piston and its rod, a crank and its connecting rod, a main valve, and means for actuating the main valve, of a cut-off valve arranged to act in conjunction with the main valve, a floating lever connected to the cut-off valve and to the main valve actuating means, so as to cause the cut-off valve when in active positions to be moved oppositely to the main valve, and a connection between the floating lever and a moving part of the engine acting in unison with the piston, whereby the speed of the cut-off valve is auxiliated. 2nd. A cut-off valve gear combined with an engine having a cylinder, a piston, connecting rod, a crank shaft and crank, main slide valve, a link motion for imparting variable movement from the crank shaft to the main valve, said valve gear comprising a floating lever, the fulcrum of which is carried by a rocking arm, means connecting the floating lever to the cut-off valve, to a connection of the link motion of the main valve, and to the piston, whereby the speed of the

cut-off valve is auxiliated when in active positions and its movement relative to the main valve is varied by the extent of travel imparted to the main valve by the link motion.

#### No. 67,168. Car Coupler. (*Attelage de churs.*)

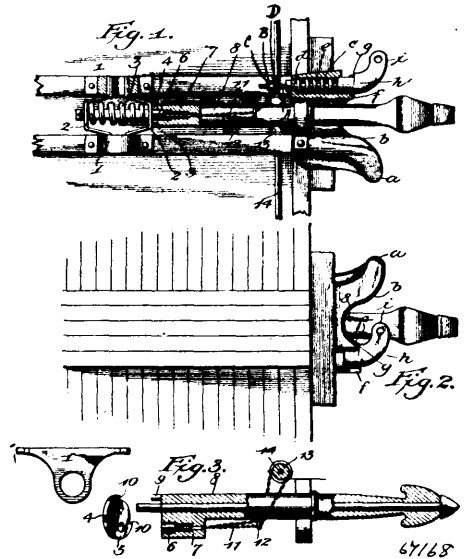

George C. Harlin, Stockton, California, U.S.A., 1st May, 1900; 6 years. (Filed 6th April, 1900.)

Claim.—1st. In a coupling, a draw bar, a sleeve thereon having an apertured flange, a housing on the extension of the draw bar, a spring pressed pin in the housing adapted to be seated in the apertures of the flange, means for limiting the rotation of the draw bar and arresting the parts when the pin registers with one of the apertures, a flexible connection secured to the end of the pin, means for withdrawing the pin and rotating the draw bar at a single operation. 2nd. In a coupling, a draw bar, a sleeve thereon having an apertured flange, a housing on the extension of the draw bar, a spring pressed pin in the housing adapted to be seated in the apertures of the flange, means for limiting the rotation of the draw bar and arresting the parts when the pin registers with one of the apertures, a flexible connection secured to the end of the pin, a shaft, a sheave pulley for attachment with the flexible connection, substantially as described. 3rd. In a coupling a draw bar, a sleeve thereon having an apertured flange, a housing on the extension of the draw bar, a spring pressed pin in the housing adapted to be seated in apertures of the flange, means for limiting the rotation of the draw bar and arresting the parts when the pin registers with one of the apertures, a flexible connection secured to the end of the pin, a shaft, a sheave pulley for attachment with the flexible connection, a guide on the extension through which the flexible connections operate, substantially as described. 4th. In a coupler, an arrow head coupler adapted to operate automatically, and a vertical hook coupler adapted to be rotated into and out of vertical alignment with the arrow head coupler, substantially as described. 5th. In a car coupler, a guide