

adjacent to one face of said mould and means adapted to form a backing for said mould, substantially as and for the purposes described. 2nd. In a quad forming attachment for linotype machines, a mould disc, a quad mould comprising a body removably secured to the disc and a cap removably secured to the body, the contiguous faces of the body and cap being provided with channels or grooves of a width corresponding to that of the quads to be produced, vice jaws located adjacent to the front face of said mould, and means for clamping said jaws together, said means forming a backing for said mould, substantially as and for the purposes described.

No. 66,868. Indexed Book. (*Livre d'index.*)

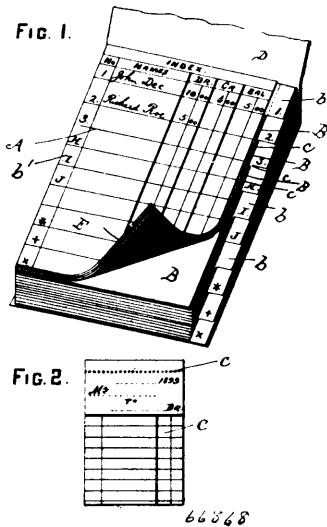

Abraham L. Yates, Niagara Falls, New York, U.S.A., 2nd April 1900; 6 years. (Filed 17th March, 1900.)

Claim.—1st. In an indexed book, the combination with a series of permanent pages provided with distinguishing marks upon extensions or tabs arranged in a stepped progression, of detachable pages arranged between the said permanent pages, and a single superposed index page bound up with all the said pages and marked to correspond with the said permanent pages, the said detachable pages and index page being arranged so as not to cover the said extension or tabs, substantially as set forth. 2nd. In an indexed book, the combination with a series of permanent pages provided with distinguishing marks upon extensions or tabs arranged in a stepped progression, of a series of detachable pages arranged in alternation with the said permanent pages, and a single superposed index page bound up with all the said pages and marked to correspond with the said permanent pages at a series of points in line with the marks on the said extensions or tabs, substantially as set forth.

No. 66,869. Wagon Brake. (*Frein de wagon.*)

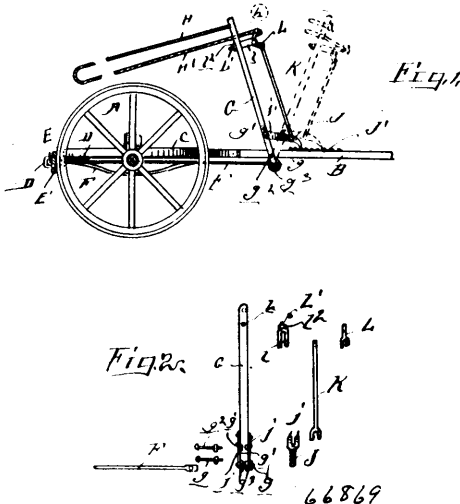

William N. Gantt and James M. Gantt, both of Liberty, South Carolina, U.S.A., 2nd April, 1900; 6 years. (Filed 3rd January, 1900.)

Claim.—1st. In combination with a brake, an elongated brake lever pivotally secured to the tongue and projecting slightly below the same, a connecting rod between the brake beam and lever, a gravity catch pivoted to said brake lever, a rack adapted to be engaged by said catch and means for independently operating the catch and brake lever respectively, substantially as described. 2nd. In combination with a brake, an operating lever pivoted to the tongue and projecting below the same, a connecting rod between the brake beam and the lower end of the brake lever, and antifriction rollers on the lower end of the brake lever, substantially as described. 3rd. In combination with a brake, of an operating lever thereof, a cable attached to the upper end of said lever, a catch pivoted directly to said operating lever near its lower end, stops adapted to be engaged by said catch to retain the lever in locked position, and a cable attached to said catch and guided by the operating lever, substantially as described.

No. 66,870. Sewing Stand. (*Table de couture.*)

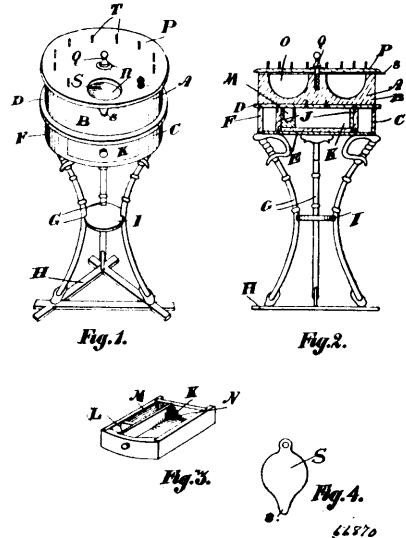

Hilkiah Martin, Preston, Ontario, Canada, 2nd April, 1900; 6 years. (Filed 28th November, 1899.)

Claim.—1st. In a sewing stand, the combination of the stand body composed of an upper portion and a lower portion, pockets formed in the upper surface of said upper portion, a revoluble cover centrally secured by a pivot to the centre of and over said upper portion and provided with a hole which registers with the pockets in said upper portion, pins secured on the upper side of said revoluble top, a cover slide swung on said pivot and between the said revoluble top and upper portion, the outer end of said cover slide extending beyond the periphery of said revoluble top, a suitably divided drawer held in said lower portion, and suitable legs secured to said lower portion for supporting the stand body, substantially as set forth and for the purpose specified.

No. 66,871. Wagon Brake. (*Frein de wagon.*)

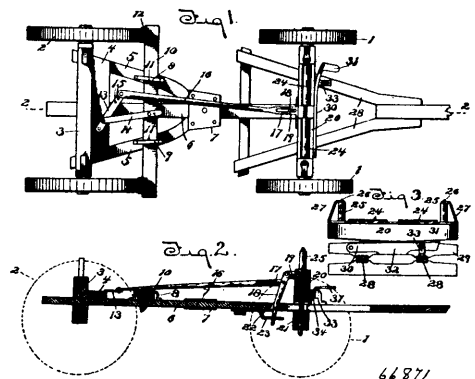

John M. Heid, Hyde, Indiana, U.S.A., 2nd April, 1900; 6 years. (Filed 26th January, 1900.)

Claim.—1st. In a wagon brake, the combination with a brake beam, of a reach adapted to move longitudinally independently of the front bolster, an arm pivotally secured to the front bolster and